

# SCXI™-1327 HIGH-VOLTAGE ATTENUATOR TERMINAL BLOCK

This guide describes how to install and use the SCXI-1327 high-voltage attenuator terminal block with the SCXI-1120, SCXI-1120D, SCXI-1121, SCXI-1125, and SCXI-1126 modules.

## Introduction

---

The SCXI-1327 high-voltage attenuator terminal block is shielded and has screw terminals that connect to the SCXI-1120, SCXI-1120D, SCXI-1121, SCXI-1125, or SCXI-1126 input connector. Each SCXI-1327 channel has a precision 100:1 resistive voltage divider that you can use to measure voltages of up to 300 V<sub>rms</sub> or ±300 VDC with the SCXI-1120, SCXI-1120D, SCXI-1121, SCXI-1125, or SCXI-1126. You can individually bypass these dividers for low-voltage measurement applications.

The terminal block has 18 screw terminals for easy signal connection. One pair of screw terminals connects to the SCXI-1120, SCXI-1120D, SCXI-1121, SCXI-1125, or SCXI-1126 chassis ground. When used with the SCXI-1120, SCXI-1120D, SCXI-1125, or SCXI-1126, the remaining eight pairs of screw terminals connect signals to the eight module inputs.

When used with the SCXI-1121, four pairs of SCXI-1327 screw terminals connect signals to four module inputs and the remaining four pairs of SCXI-1327 screw terminals connect signals to four module excitation outputs.





**Note** For correct operation with the SCXI-1121 module, you must bypass the attenuators on the excitation channels.

# Conventions

---

The following conventions are used in this guide:

- » The » symbol leads you through nested menu items and dialog box options to a final action. The sequence **File»Page Setup»Options** directs you to pull down the **File** menu, select the **Page Setup** item, and select **Options** from the last dialog box.
-  This icon denotes a note, which alerts you to important information.
-  This icon denotes a caution, which advises you of precautions to take to avoid injury, data loss, or a system crash.
- bold** Bold text denotes items that you must select or click on in the software, such as menu items and dialog box options.
- italic* Italic text denotes variables, emphasis, a cross reference, or an introduction to a key concept. This font also denotes text that is a placeholder for a word or value that you must supply.
- monospace Text in this font denotes text or characters that you should enter from the keyboard, sections of code, programming examples, and syntax examples. This font is also used for the proper names of disk drives, paths, directories, programs, subprograms, subroutines, device names, functions, operations, variables, filenames and extensions, and code excerpts.

## What You Need to Get Started

---

To set up and use your SCXI-1327 terminal block, you need the following items:

- SCXI-1327 high-voltage attenuator terminal block
- SCXI-1327 High-Voltage Attenuator Terminal Block Installation Guide*
- SCXI chassis
- One of the following modules:
  - SCXI-1120
  - SCXI-1120D
  - SCXI-1121
  - SCXI-1125
  - SCXI-1126

- Number 1 and 2 Phillips-head screwdrivers
- 1/8 in. flathead screwdriver
- Long-nose pliers
- Wire cutter
- Wire insulation stripper

## Safety Information

---



**Cautions** Do *not* operate the device in an explosive atmosphere or where there may be flammable gases or fumes.

Keep away from live circuits. Do *not* remove equipment covers or shields unless you are trained to do so. If signal wires are connected to the device, hazardous voltages can exist even when the equipment is turned off. To avoid a shock hazard, do *not* perform procedures involving cover or shield removal unless you are qualified to do so and disconnect all field power prior to removing covers or shields.

Equipment described in this document must be used in an Installation Category II<sup>1</sup> environment per IEC 60664-1. This category requires local level supply mains-connected installation.

Do *not* operate damaged equipment. The safety protection features built into this device can become impaired if the device becomes damaged in any way. If the device is damaged, turn the device off and do *not* use it until service-trained personnel can check its safety. If necessary, return the device to National Instruments for service and repair to ensure that its safety is not compromised.

Do *not* operate this equipment in a manner that contradicts the information specified in this document. Misuse of this equipment could result in a shock hazard.

Do *not* substitute parts or modify equipment. Because of the danger of introducing additional hazards, do *not* install unauthorized parts or modify the device. Return the device to National Instruments for service and repair to ensure that its safety features are not compromised.

When using the device with high common-mode voltages, you *must* insulate your signal wires for the highest input voltage. National Instruments is *not* liable for any damages or injuries resulting from inadequate signal wire insulation. Use only 26-14 AWG wire with a minimum voltage rating of 300 V and a temperature value of 60 °C for measuring up to 300 V.

---

<sup>1</sup> Category II refers to local-level power distribution, such as that provided by a standard wall outlet.

When connecting or disconnecting signal lines to the SCXI terminal block screw terminals, make sure the lines are powered off. Potential differences between the lines and the SCXI ground can create a shock hazard while you connect the lines.

Connections, including power signals to ground and vice versa, that exceed any of the maximum signal ratings on the SCXI device can create a shock or fire hazard, or can damage any or all of the boards connected to the SCXI chassis, the host computer, and the SCXI device. National Instruments is *not* liable for any damages or injuries resulting from incorrect signal connections.

If hazardous voltages ( $\geq 30 V_{\text{rms}}$  and  $42.4 V_{\text{peak}}$  or 60 VDC) are present, you *must* connect a safety earth-ground wire to the terminal block safety-ground lug, shown in Figure 1. This complies with safety agency requirements and protects against electric shock when the terminal block is not connected to the chassis. To connect the safety earth-ground to the safety-ground lug, run an earth-ground wire from the signal source to the terminal block. National Instruments is *not* liable for any damages or injuries resulting from inadequate safety earth-ground connections.

Do *not* loosen or re-orient the safety-ground lug hardware when connecting the safety-ground wire; to do so reduces the safety isolation between the high voltage and safety ground.

Clean the module and accessories by brushing off light dust with a soft non-metallic brush. Remove other contaminants with a stiff non-metallic brush. The unit *must* be completely dry and free from contaminants before returning it to service.

The terminal block *must* be used with a UL-listed SCXI chassis.

## Configuring the High-Voltage Attenuator

---

Each channel has a 100:1 high-voltage attenuator that you can enable or disable by changing switch settings as shown in Table 1. Each channel requires two switches that you must set in the same position for the attenuator to operate correctly. The switches are behind their corresponding terminals.

- Set both switches to the 100:1 position to attenuate the appropriate channel. This setting places a precision 100:1 divider in the circuit to divide the voltage by 100 before the voltage enters the module.
- Set both switches to the 1:1 position to bypass the attenuator of the appropriate channel. This setting removes the 100:1 divider from the input stage.

**Table 1.** SCXI-1327 High-Voltage Attenuator Configuration

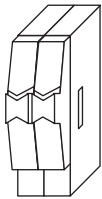
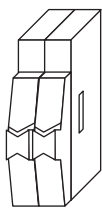
Switch Position	Description
 100:1 1:1	Enables the attenuator for a specific channel. This is the default setting.
 100:1 1:1	Bypasses the attenuator for a specific channel.



**Note** For correct operation with the SCXI-1121 module, you must bypass the attenuators on the excitation channels.

## Connecting Signals



**Caution** Refer to the [Safety Information](#) section before removing equipment covers or connecting or disconnecting any signal wires.

To connect the signal to the terminal block, perform the following steps, referring to Figures 1 and 2 as necessary:

1. Unscrew the top cover screws and remove the top cover.
2. Loosen the strain-relief screws and remove the strain-relief bar.
3. Prepare your signal wire by stripping the insulation no more than 7 mm.

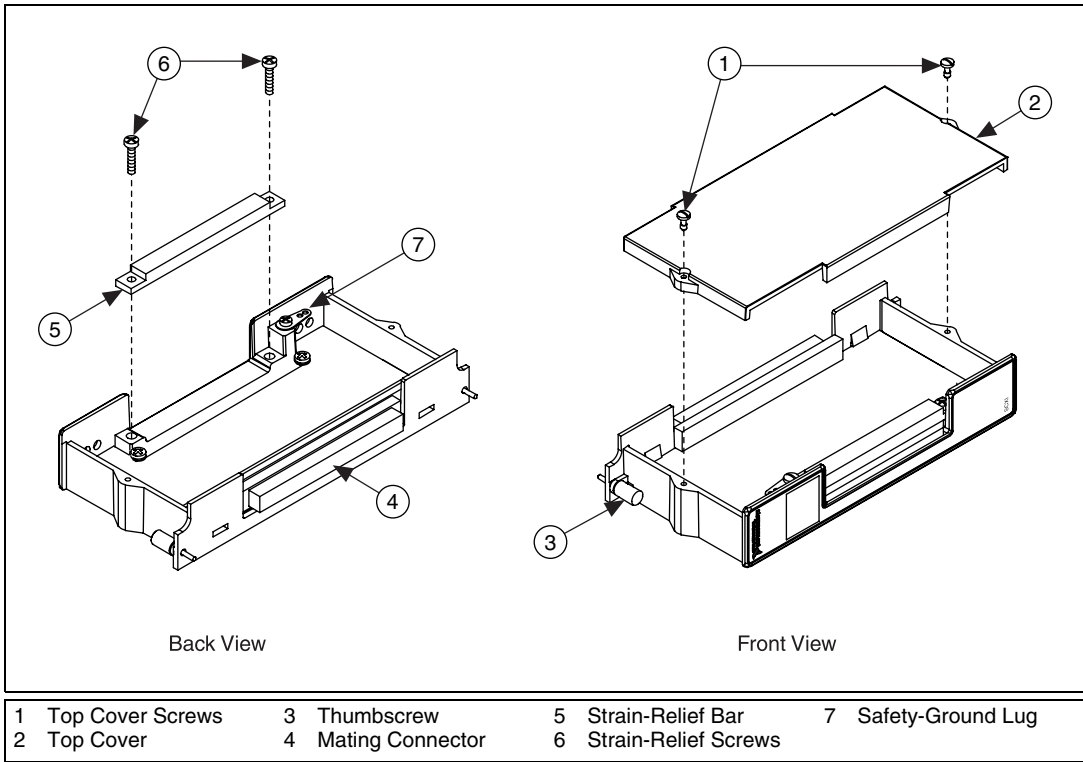
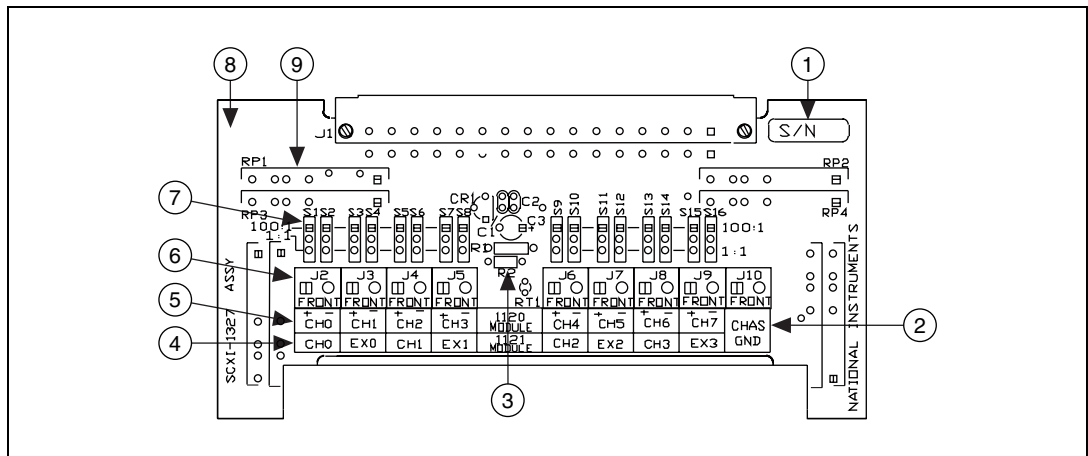

**Figure 1.** SCXI-1327 Parts Locator Diagram

- Run the signal wires through the strain-relief opening. You can add insulation or padding if necessary.



**Note** When connecting your signals to the SCXI-1327, follow the labeling on the SCXI-1327 for the appropriate module, as indicated in Figure 2.



1	Serial Number	6	Screw Terminals
2	Chassis Ground	7	Switches to Enable or Bypass the Attenuator
3	Thermistor	8	Product Name, Assembly Number, and Revision Letter
4	Channel Labeling for the SCXI-1121	9	Voltage Dividers
5	Channel Labeling for the SCXI-1120, SCXI-1120D, SCXI-1125, SCXI-1126		

**Figure 2.** SCXI-1327 Signal Connections

5. Connect the signal wires to the screw terminals by inserting the stripped end of the wire fully into the terminal. No bare wire should extend past the screw terminal. Exposed wire increases the risk of short circuits and equipment failure.
6. Configure your high-voltage attenuator as explained in the [Configuring the High-Voltage Attenuator](#) section.
7. Tighten the screws to a torque of 5–7 in.-lb.
8. Connect the safety earth-ground to the safety-ground lug. Refer to the [Safety Information](#) section for connection information.
9. Reinstall the strain-relief bar and tighten the strain-relief screws.
10. Reinstall the top cover and tighten the top cover screws.
11. Connect the terminal block to the module front connector as explained in the [Installing the Terminal Block](#) section.

# Installing the Terminal Block

---

To connect the terminal block to the SCXI module front connector, perform the following steps:

1. Connect the module front connector to its mating connector on the terminal block.
2. Tighten the top and bottom thumbscrews on the back of the terminal block to hold it securely in place.



**Note** For accurate cold-junction compensation, place the SCXI chassis away from an extreme temperature differential.

# Cleaning the Terminal Block

---

Clean the terminal block by brushing off light dust with a soft, nonmetallic brush. Remove other contaminants with deionized water and a stiff nonmetallic brush. The unit must be completely dry and free from contaminants before returning it to service.

# Calibrating the Terminal Block

---

For information on calibrating the SCXI-1327, see the *SCXI-1327 High-Voltage Attenuator Terminal Block Calibration Procedure* located online at [ni.com/calibration](http://ni.com/calibration) and follow the link for *Manual Calibration Procedures*.

# Specifications

---

All specifications are typical at 25 °C unless otherwise specified.

## Electrical

Compatible modules

SCXI-1120/1120D.....	8 input channels
SCXI-1121.....	4 input channels, 4 excitation output channels
SCXI-1125.....	8 input channels
SCXI-1126.....	8 input channels

### Cold-junction temperature-sensor circuitry

Sensor type.....	Thermistor
Output range .....	1.91 to 0.65 VDC from 0 to 50 °C
Accuracy <sup>1</sup> .....	±0.9 °C from 15 to 35 °C ±1.3 °C from 0 to 15 °C and 35 to 50 °C
Repeatability .....	±0.5 °C from 15 to 35 °C
Maximum temperature gradient between sensor and any terminal ....	±0.4 °C (non-isothermal)

### High-voltage attenuator

Attenuation ratio .....	100:1 or 1:1 (selectable on a per-channel basis using slide switches)
Attenuation ratio accuracy .....	±0.06% (for 100:1 setting)
Attenuation ratio temperature drift .....	15 ppm/°C
Resistance between CH- and CH+ terminals	
1:1 attenuation setting.....	Determined by attached module
100:1 attenuation setting.....	1 MΩ

Coupling..... DC only

Current-receiver resistors ..... Resistors not included,  
resistor sockets not provided

### Maximum working voltage (signal + common-mode)

Channel-to-ground voltage .....	Each channel to remain within 300 V <sub>rms</sub> or ±300 VDC of the ground
Channel-to-channel voltage .....	Each channel to remain within 300 V <sub>rms</sub> or ±300 VDC of the voltage applied to any other channel

---

<sup>1</sup> This includes the accuracy of the temperature sensor itself (±0.5 °C) and the temperature difference between the sensor and any screw terminal (which may be as large as ±0.4 °C).

## Field-wiring connectors

### Screw terminals

Signal terminals.....	16 (8 pairs)
Functional ground terminals.....	2
Maximum wire gauge.....	16 AWG
Terminal spacing .....	0.5 cm (0.2 in.) center-to-center
Dimensions of front entrance .....	1.2 by 7.3 cm (0.47 by 2.87 in.)
Solder pads for additional components .....	None
Safety earth-ground lugs.....	1
Strain relief .....	Strain-relief bar at terminal-block entrance

## Mechanical

Dimensions .....	17.8 by 7.94 by 3.0 cm (7.0 by 3.125 by 1.2 in.)
Weight .....	200 g (7 oz)

## Environmental

Operating temperature .....	0 to 50 °C
Storage temperature .....	-20 to 70 °C
Relative humidity .....	5 to 90% noncondensing
Altitude (maximum) .....	2000 m

## Safety

Designed in accordance with IEC 61010-1, UL 3111-1, and CAN/CSA C22.2 No. 1010.1 for electrical measuring and test equipment.  
Installation category II  
Pollution degree 2

## Electromagnetic Compatibility

EMC/EMI.....	CE, C-Tick, and FCC Part 15 (Class A) Compliant
Electrical emissions.....	EN 55011 Class A at 10 m FCC Part 15A above 1 GHz
Electrical immunity.....	Evaluated to EN 61326:1998, Table 1



**Note** This device should only be operated with shielded cabling for full EMC and EMI compliance. See the *Declaration of Conformity* for this product for any additional regulatory compliance information.

## Temperature Sensor Output and Accuracy

---

The SCXI-1327 temperature sensor outputs 1.91 to 0.65 V from 0 to 50 °C.

### Converting a Thermistor Voltage to a Temperature

National Instruments software can convert a thermistor voltage to the thermistor temperature for the circuit diagram shown in Figure 3. In LabVIEW, you can use the Convert Thermistor Reading VI that is found in the **Data Acquisition»Signal Conditioning** palette. If you are using CVI or NI-DAQ, use the `Thermistor_Convert` function. The VI takes the output voltage of the temperature sensor, the reference voltage, and the precision resistance and returns the thermistor temperature.

Alternatively, you can use the following formulas:

$$T(^{\circ}\text{C}) = T_K - 273.15$$

where  $T_K$  is the temperature in Kelvin

$$T_K = \frac{1}{[a + b(\ln R_T) + c(\ln R_T)^3]}$$

$$a = 1.295361 \times 10^{-3}$$

$$b = 2.343159 \times 10^{-4}$$

$$c = 1.018703 \times 10^{-7}$$

$R_T$  = resistance of the thermistor in ohms

$$R_T = 5,000 \left( \frac{V_{TEMPOUT}}{2.5 - V_{TEMPOUT}} \right)$$

$V_{TEMPOUT}$  = output voltage of the temperature sensor

$$T(^{\circ}F) = \frac{[T(^{\circ}C)]9}{5} + 32$$

where  $T(^{\circ}F)$  and  $T(^{\circ}C)$  are the temperature readings in degrees Fahrenheit and degrees Celsius, respectively.



**Note** Use an average of a large number of samples to obtain the most accurate reading. Noisy environments require more samples for greater accuracy.

## Reading the Temperature Sensor in LabVIEW

In LabVIEW, the channel string used to read  $V_{TEMPOUT}$  depends on which module is connected to the SCXI-1327. For more information about channel-string arrays and the SCXI channel-addressing syntax, see the *LabVIEW Measurements Manual*.



**Note** This section is not applicable to the SCXI-1126.

- With the SCXI-1120, SCXI-1120D, or SCXI-1121, use the address string:

`obx ! scy ! mdz ! mtemp`

This channel-address string *cannot* be in the same channel-string array as other channels on the module that is being addressed.

- With the SCXI 1125, use the address string:

`obx ! scy ! mdz ! cjtemp`

This channel-address string can be in the same channel-string array as other channels on the same SCXI-1125 module and may be called multiple times within the same channel-string array.

# Temperature Sensor Circuit Diagram

You do *not* need to read this section to operate the SCXI-1327. The circuit diagram in Figure 3 is optional information that you can use if you want more details about the SCXI-1327 temperature sensor.

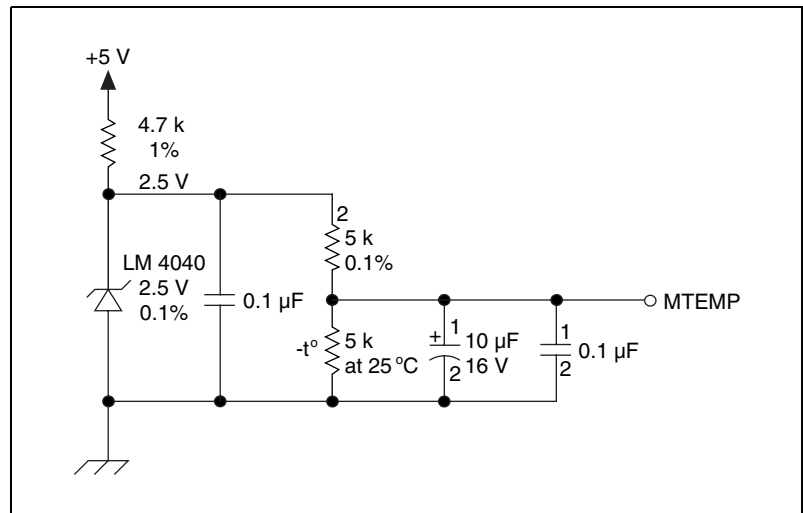

**Figure 3.** Temperature Sensor Circuit Diagram

# Technical Support Resources

---

## NI Web Support

National Instruments Web support is your first stop for help in solving installation, configuration, and application problems and questions. Online problem-solving and diagnostic resources include frequently asked questions, knowledge bases, product-specific troubleshooting wizards, manuals, drivers, software updates, and more. Web support is available through the Technical Support section of [ni.com](http://ni.com)

## Worldwide Support

National Instruments has offices located around the world to help address your support needs. You can access our branch office Web sites from the Worldwide Offices section of [ni.com](http://ni.com). Branch office Web sites provide up-to-date contact information, support phone numbers, e-mail addresses, and current events.

If you have searched the technical support resources on our Web site and still cannot find the answers you need, contact your local office or National Instruments corporate. For telephone support in the United States, dial 512 795 8248. For telephone support outside the United States, contact your local branch office:

Australia 03 9879 5166, Austria 0662 45 79 90 0, Belgium 02 757 00 20,  
Brazil 011 284 5011, Canada (Calgary) 403 274 9391,  
Canada (Ontario) 905 785 0085, Canada (Québec) 514 694 8521,  
China 0755 3904939, Denmark 45 76 26 00, Finland 09 725 725 11,  
France 01 48 14 24 24, Germany 089 741 31 30, Greece 30 1 42 96 427,  
Hong Kong 2645 3186, India 91805275406,  
Israel 03 6120092, Italy 02 413091, Japan 03 5472 2970,  
Korea 02 596 7456, Mexico (D.F.) 5 280 7625,  
Mexico (Monterrey) 8 357 7695, Netherlands 0348 433466,  
New Zealand 09 914 0488, Norway 32 27 73 00, Poland 0 22 528 94 06,  
Portugal 351 1 726 9011, Singapore 2265886, Spain 91 640 0085,  
Sweden 08 587 895 00, Switzerland 056 200 51 51,  
Taiwan 02 2528 7227, United Kingdom 01635 523545



321930C-01

Oct00